



**Mallorquinas**  
Folding / Folding and sliding / Sliding  
Projectable / "Z"





## Our Company

For 50 years we have provided to our company with the last technologies in manufacture methods to obtain a first quality product.

With this magazine we put in Knowledge of our clients the most competitive products placed in the first line on the market that we have obtained during this time.

## I+D+I

Our R+D department and professional staff always get the highest performance together with last generation technologies, we apply R+D to any of our products.

New lines of products are created as a result of this management in wich nowadays, final touch and qualities are our first priorities to reach.

## Production

Nowadays, we not only distribute our products in our area, but also in Spain and other twenty countries, above all American countries.

The prestige of our products together with our perfect organization in administration, manufacturing, delivering and customer service has turned us into the first enterprise of the sector at a national level.

## CE Marked

Gimenez Ganga informs you that it is certificated with the corresponding stamp of the CE the following models of doors: PS-64, PS-65, PS-75, PS-78, PS-79, PS-80, PS-100, PS-110, with their variants of installation covering a total of 15 models.



# SANALUZ



## INDEX

### MALLORQUINA FOLDING LEAF

---

03

Fixed or Mobile slat

### MALLORQUINA FOLDING AND SLIDING

---

05

Fixed or Mobile slat

### MALLORQUINA SLIDING

---

07

Fixed or Mobile slat

### MALLORQUINA PROJECTED

---

09

Fixed or Mobile slat

### SHAPES AND OPTIONS

---

11



Mallorquina 4 folding leaves.  
Mobile slat.



Mallorquina 3 folding leaves.  
Fixed slat.

FOLDING



# MALLORQUINA FOLDING

We can combine fixed D-5 and mobile D-7.



Slats position detail.



Hinge detail.

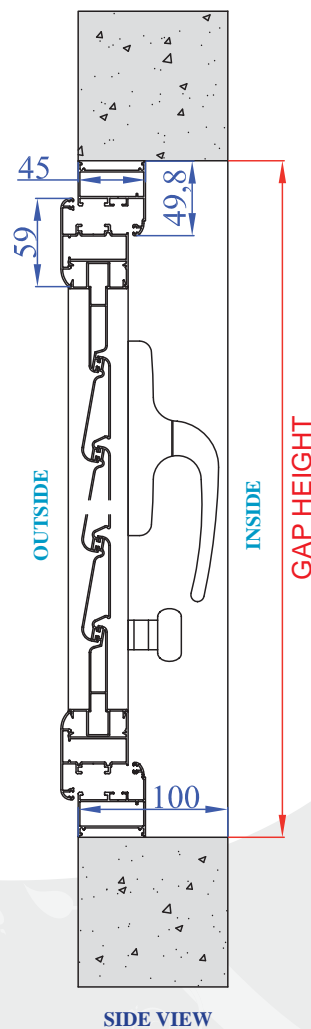
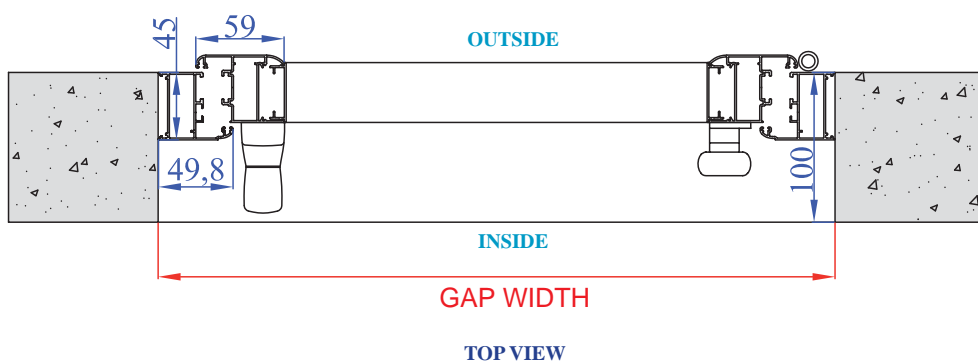

**This system allows it to have the mobile D-7 in fixed extrustructure.**

TECHNICAL CHARACTERISTICS	
Frame dimensions	45 x 49,8 mm.
Leaf dimensions	45 x 59 mm.
Types	Fixed: D-5. Mobile: D-7 Aluminium.
Advisable width	800 mm. (Per leaf)
Advisable height	2500 mm. leaf (with a crossbar separated). From 1,40 mtr. 3 hinges.
Accessories	White and black.
Nº of leaves	1, 2, 3 and 4 leaves.
Inside ending	30, 50 and 80 mm.

\* Consult other model as long as the gap allows.



# FOLDING AND SLIDING



Mallorquina folding and sliding, 3 leaves.  
Available with as many leaves as the client please.





# MALLORQUINA FOLDING AND SLIDING

You can have as many leaves as you please.



Hinge detail.



Hinge detail.

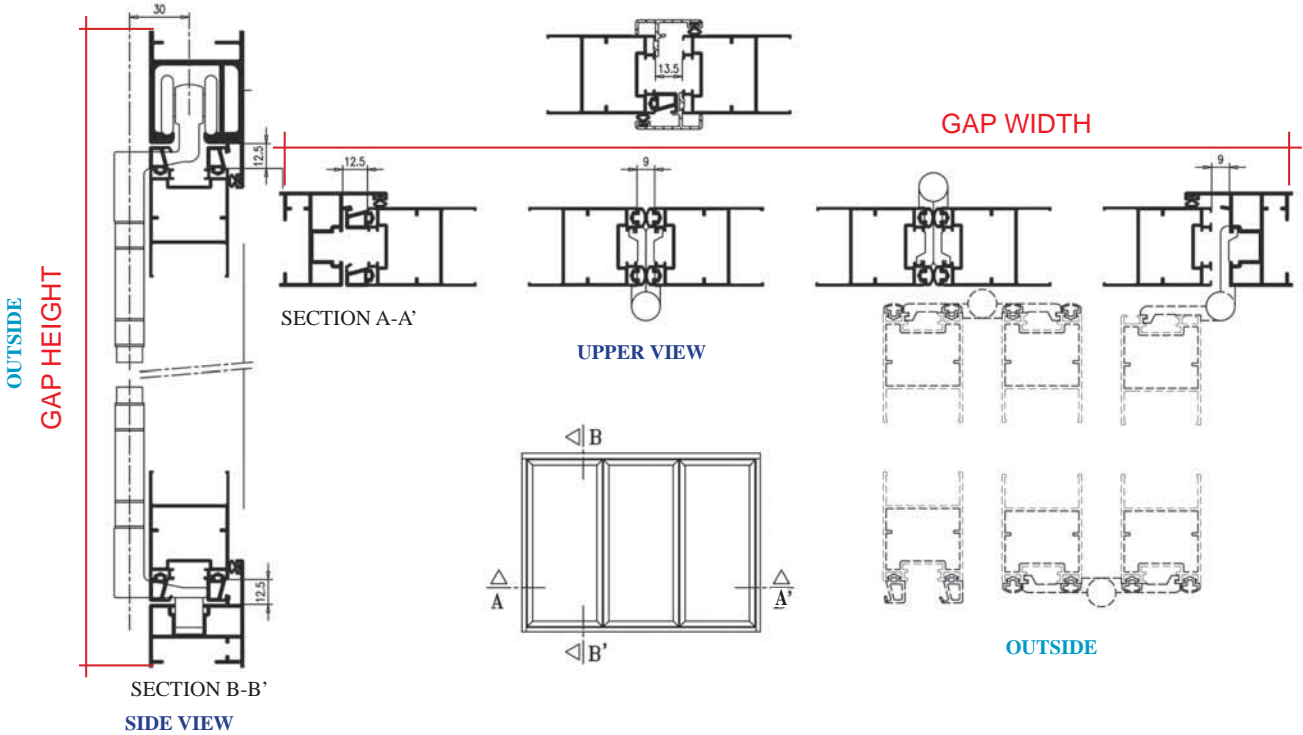

TECHNICAL CHARACTERISTICS	
Frame dimensions	47,5 x 54,2 mm.
Leaf dimensions	40 x 55 mm.
Types *	Fixed: D-5 Aluminium. Mobile: D-7 Aluminium
Advisable width	750 mm. leaf (minimum 2 leaves)
Advisable height	2500 mm. leaf.
Accessories	White and black.
Flashing	36 mm.
Lower termination	Different possibilities both with inlayed or surface guide.

**This mallorquina has a strong profile, moreover it allows you to have even and odd sheets.**

\* Consult other model as long as the gap allows.



Upper profile detail.



Sliding mallorquina 1 leaf.



Lower profile detail.

SLIDING





Insulation detail.

## MALLORQUINA SLIDING

Mallorquina especially designed for the outside of the facade, contributing to the edification with a stunning appearance.

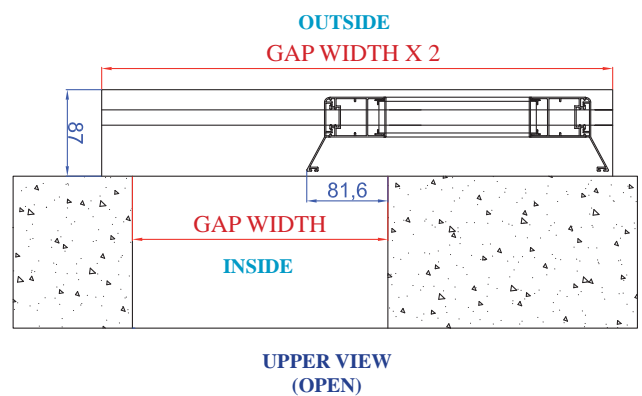
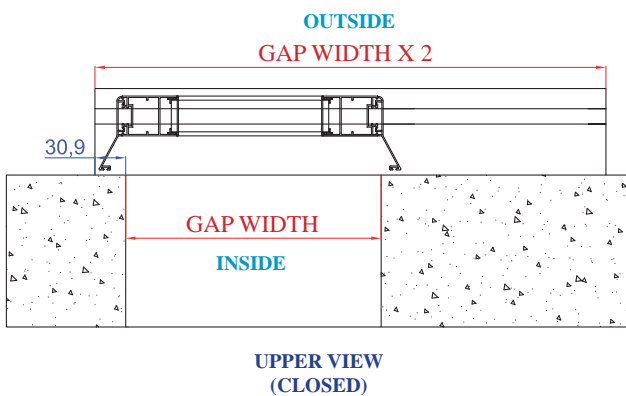

Allows to save energy because radiates the heat absorbed to the exterior of the building.

TECHNICAL CHARACTERISTICS	
Frame dimensions	47,5 mm.
Leaf dimensions	47,5 mm.
Types *	Fixed: D-5 Aluminium. Mobile: D-7 Aluminium.
Advisable width	Leaves are divided in modules of 800 mm.
Advisable height	2500 mm. leaf (break though a 2 parts crossbar to install 2 mechanism or more).
Accessories	White and black.
Nº of leaves	1 rail: 1 and 2 leaves; 2 rails: 2, 3 and 4 leaves.
Lower termination	Different possibilities both with inlayed or surface guide.

\* Consult other model as long as the gap allows.

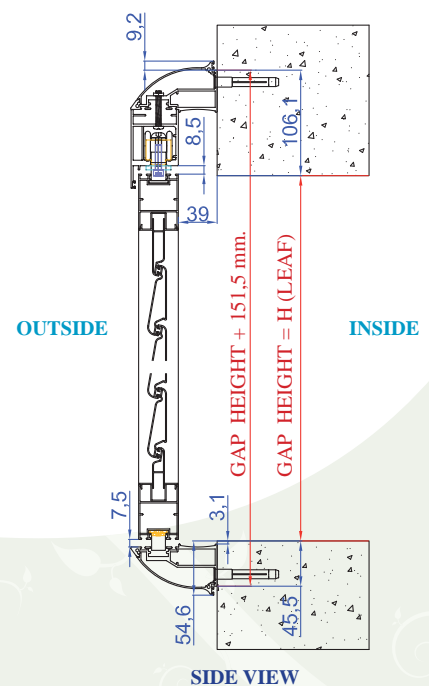



Opening detail.



PROJECTED



## PROJECTED

Mallorquina model with front functional and comfortable.

**It allows to install fixed slats or mobile slats.**





• Upper fixed

Semicircular •



• Redouce point



Carpanel 2 Radios •



• Moon (shape)

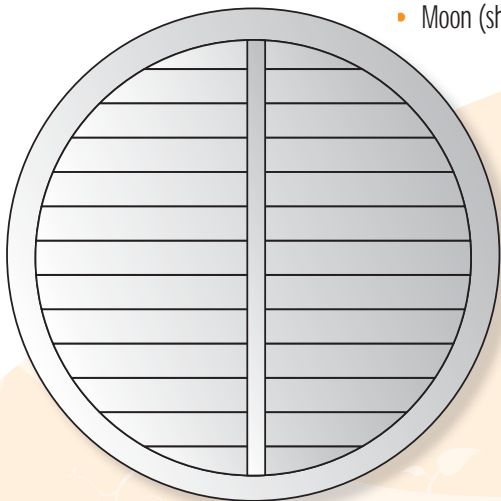



## SHAPES

Mallorquina combines the functionality of roller shutter with the safety and aesthetics of a windows.

Pyramidal •

**It allows you to have many different shapes and position.**

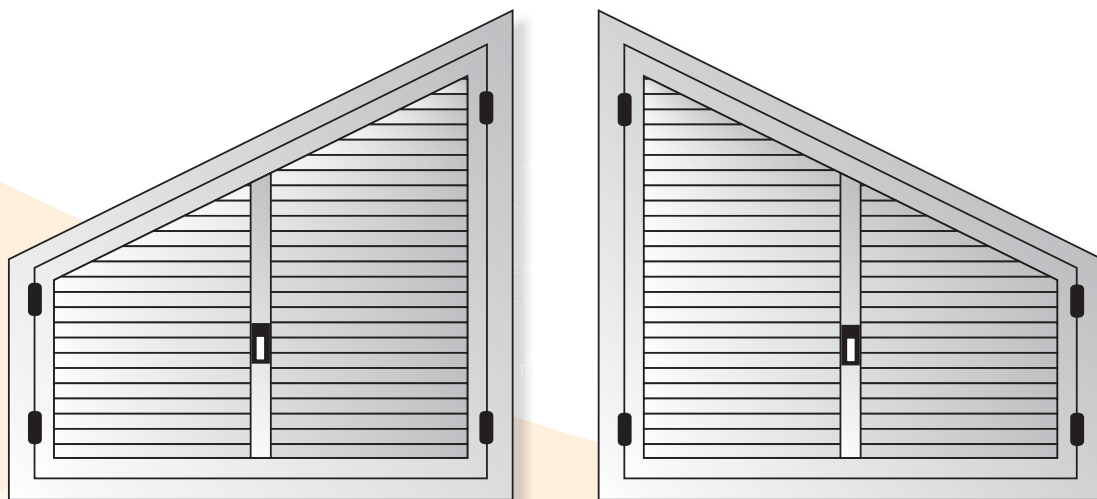
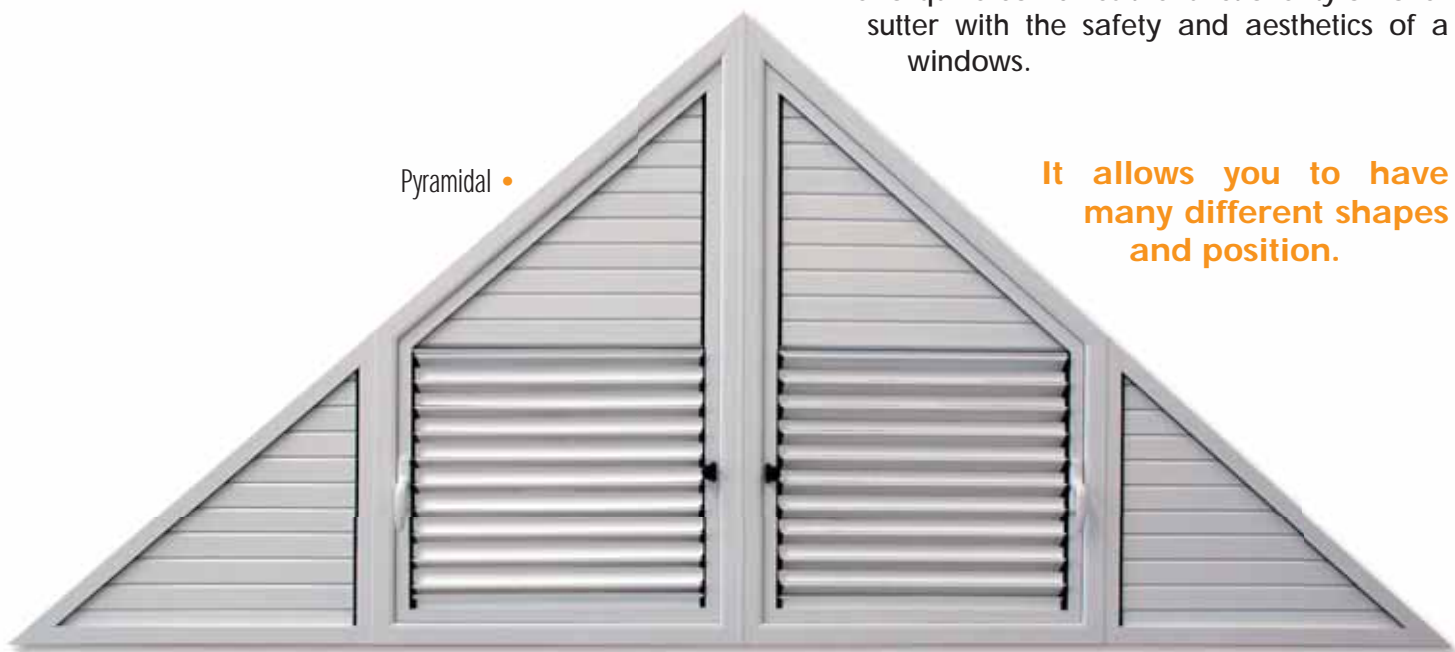

• Keystone

# SANALUZ



**GIMENEZ GANGA**

[www.gimenezganga.com](http://www.gimenezganga.com)

